

STEEPLAND HARVESTING PROGRAMME

POST-PROGRAMME REPORT 2018



31 July 2018



Ministry for Primary Industries
Manatū Ahu Matua



Steep Land Harvesting Programme

Annual Programme Report

to 30 June 2018

Acknowledgements: Steepland Harvesting was a Primary Growth Partnership between the Ministry for Primary Industries (MPI) and the forest industry led by Forest Growers Research Ltd (FGR). This annual post-programme outcomes report details progress towards achieving short term outcomes to 2018 and medium term outcomes. This report is a contractual obligation of the programme until 30 June 2020. FGR acknowledges the support of all stakeholders in the forest industry in providing information contained within this report.

TABLE OF CONTENTS

1. EXECUTIVE SUMMARY	4
1.1. Introduction.....	4
1.2. Programme Objectives	4
1.3. Key Achievements from 2017/18	4
1.4. Outcomes	6
2. PGP STEEPLAND HARVESTING PROGRAMME	8
2.1. Programme Goals and Objectives	8
2.2. Programme Related Activities in 2017/18	8
3. OUTCOMES	16
3.1. Short Term Outcomes.....	16
3.2. Medium Term Outcomes	17
4. BENEFITS	20
4.1. Economic Benefits	20
4.2. Forest Machinery Sales	21
4.3. Spillover Benefits	21
5. POST PGP PROGRAMME ACTIVITIES.....	21
5.1. Other Activities.....	21
5.2. Conclusions	22
5.3. Further Post-programme Reporting	22
5.4. Programme Evaluation	22
6. REPORTS AND CONFERENCE PRESENTATIONS 2017/18.....	23

1. EXECUTIVE SUMMARY

1.1. Introduction

In 2010 the New Zealand forestry sector and the Government both identified steep country harvesting as the key bottleneck in achieving greater profitability in forestry. They determined that harvesting costs needed to be reduced by 25%; that the harvest machinery industry in New Zealand must substantially grow to future-proof the industry; and that harvesting jobs must be made safer and more desirable for workers.

Future Forests Research Ltd (now Forest Growers Research) formed a Primary Growth Partnership programme (PGP) with MPI to realise the vision in steep terrain harvesting of 'no worker on the slope, no hand on the chainsaw'. This vision is now being achieved through the implementation of innovative mechanised and remote controlled harvesting technologies to realise substantial safety, productivity and cost reduction gains and improve worker safety in steep terrain harvesting in New Zealand.

Steepland Harvesting commenced in July 2010 and was completed on 30 September 2017. Total programme funding was \$7.60 million (\$3.92 million from the forest industry and \$3.68 million from government).

This annual post-programme outcomes report details progress towards achieving short term outcomes (to June 2018) and is a contractual obligation of the programme.

1.2. Programme Objectives

The goals of the programme were to improve harvesting productivity and worker safety by developing and commercialising a range of new harvesting technologies in the tree felling and extraction phase of steep country harvesting operations.

The outcomes expected by the end of the programme included:

- A 25% reduction in steep land harvesting costs. This would create operational savings of \$8.00 per cubic metre of wood produced.
- Zero lost time injuries during felling, breaking out and extraction phases of steep country harvesting.
- A 10% reduction in fuel costs.
- Developing and commercialising new machinery types for the harvesting industry for both domestic and export sales.
- Cumulative net economic benefits of \$365 million by 30 June 2018.

1.3. Key Achievements from 2017/18

Notable sector-wide achievements (from the PGP programme and other activities) include the development and commercialisation of machinery and equipment designed to improve both safety and productivity on steeper slopes. In total the sector has supported 21 development projects (including 13 from the PGP programme). Of these projects, 16 products have been commercialised

KEY FACTS

- **Forest Growers Research**
Commercial partner
- **7 years**
Programme length
- **\$7.60 million**
Total funding
- **\$3.68 million**
MPI funding
- **\$3.92 million**
Industry funding

HIGHLIGHTS

updated to 30/6/2018

- **30%** increase in cable harvesting productivity since 2010 (29.4 m³/hr in 2016 vs. 22.6 m³/hr in 2010)
- **35%** of cable harvesting operations now using mechanised felling (up from 1% in 2010)
- **53%** reduction in the number of notifiable injury and serious harm incidents in 2017 compared to 2012
- **213** workers removed from hazardous manual roles (approx. 15% of workers)
- **\$111 million** investment in new harvesting technology since 2012
- **\$230 million** total net economic benefits from 2010 – 2018

(including 7 commercial products from the PGP programme). In addition, the industry has developed 4 prototypes (3 from the PGP programme) in various stages of commercialisation, from pre-commercial model ready for market launch to early prototype requiring further investment.

- **ClimbMAX Steep Slope Harvester** – a single winch-assist unit integrated into the track frame of a felling machine. To date 11 units have been sold (8 exported).
- **Tractionline Winch Assist** – Dual winch assist system mounted on a hydraulic excavator. To date 71 units have been sold (including 36 exported).
- **Falcon Hydraulic Winch Assist** – a single winch system mounted on a hydraulic excavator. To date 55 units have been sold (including exports)
- **Remote Operated Bulldozer (ROB)** – Dual winch assist system mounted on a hydraulic bulldozer. To date 32 units have been sold (22 exported)
- **Waka Winch Assist (Waikouaiti)** – An excavator-based single winch assist system. To date 6 units have been sold (all in NZ).
- **Performance Mechanical & Engineering Ltd (Taupo)** – a double drum mechanical winch assist system mounted on a Komatsu bulldozer. To date 2 units have been sold (both in NZ).
- **HarvestNav machine navigation system** – an on-board computer tablet-based navigation system that displays real time location and multiple operating alarms. Commercially available from Margules Groome Ltd. To date 18 have been implemented as downloaded ‘app’ and 2 new full systems have been sold.
- **ATL Full Teleoperation** – a trailer-based teleoperation control system for a John Deere model 909 feller buncher. Commercially available from Applied Teleoperation Ltd.
- **ATL Cab Assist Backline** – a teleoperation control system for a mobile tail hold machine, enabling the yarder operator to shift the tail hold machine from the yarder cab. The first unit has been sold and is commercially available from Applied Teleoperation Ltd.
- **Robotic tree-to-tree prototype** – proof-of-concept prototype for a radically new felling machine, which uses movement from tree-to-tree to traverse steep terrain. Designed by Scion and built by University of Canterbury Mechatronics programme. The prototype needs further investment to develop further.
- **ATL CutoverCam hauler vision system** – an in-cab hauler vision system streaming live video of the log extraction site to the hauler operator. Commercially available from Applied Teleoperation Ltd. To date 4 systems have been sold.
- **Falcon Grapple Camera** – a robust remote controlled camera system for operation on a mechanical grapple or hydraulic grapple carriage, developed by DC Equipment Ltd (Nelson). To date about 50 units have been sold.

- Hawkeye Grapple Camera – integrated into the Hawkeye Grapple Carriage this digital camera system also features LED lighting. Commercially available from EMS Ltd (Rotorua). To date 20 units have been sold (including exports).
- Alpine Grapple Carriage – a remote controlled light weight hydraulic log grapple designed and built by Alpine Logging Equipment Ltd (South Africa). Tested, modified and trialled in NZ. To date 13 units have been sold in NZ by Alpine’s NZ agent, Logpro Ltd.
- Falcon Claw Grapple Carriage – a motorised hydraulic grapple carriage, developed by DC Equipment Ltd (Nelson). To date 42 units have been sold (including exports)
- Hawkeye Grapple Carriage – a motorised hydraulic grapple carriage, developed by EMS Ltd (Rotorua). To date 20 units have been sold (including exports).
- Falcon Tension Monitoring ‘app’ – Prototype developed at University of Canterbury. Two units have been installed in hauler cabs to monitor, record and display in the operator’s cab the working tensions of the cable skyline. This application will be commercialised by DC Equipment Ltd later in 2018, and will be integrated into the Falcon Winch Assist system.
- Skyshifter Tail Hold Carriage – Prototype twin winch tail hold carriage that can remotely control the lateral shifting of the hauler skyline. The prototype has been designed and built by Awdon Technologies Ltd (Gisborne) and is available for operational trialling and lease.
- Doherty Quick Coupler – an automatic hydraulic quick coupler for rapid changeover from grapple processor head to log loading grapple, without the operator having to leave the cab. The first unit has been sold and is commercially available from Doherty Engineered Attachments Ltd and serviced by Total Hydraulic Solutions Ltd (Rotorua).
- Falcon Felling Carriage – Prototype skyline carriage designed to fell and extract trees, and developed by DC Equipment Ltd (Nelson). Planned for commercial production and sale later in 2018.

1.4. Outcomes

The successful commercialisation of new products and processes is aimed at improving the productivity and reducing the cost of steepland harvesting, and eliminating dangerous manual labour roles. The major outcomes have been the implementation of new processes for winch-assisted felling machinery on steep slopes and increased industry uptake of grapple yarding as an improved method of cable log extraction.

Overall the sector has supported the development of 16 commercialised models of new machinery and equipment. Total number of units of all new technology sold exceeds 400, of which about 120 units have been exported. From 2012 to 2018 over \$111 million has been invested by industry in new harvesters, winch-assist machinery, grapples, cameras and other equipment designed to enable safe work in tree felling and extraction.

As a result of these new processes, mechanised felling is now replacing manual tree fallers wherever possible. With this investment, mechanised felling is now present in 80% of ground-based harvesting operations and in almost 30% of hauler operations. Overall the proportion of mechanised felling has increased from 23% of all harvesting operations in 2009 to approx. 55% of operations in 2016. Over 200 workers have been removed from the hazardous roles of tree felling and breaking out.

These sector-wide developments provide innovative harvesting solutions for steep country harvesting and fulfil the objectives of the original Business Plan of February 2010 – to improve productivity and safety on steep slopes. The adoption of this new technology has seen cable harvesting productivity increase by 30% since 2010 when the programme started.

The sector-wide net economic benefits arising from the programme and other activities are estimated to total almost \$230 million to 30 June 2018 against the goal in the business case of \$365 million.

These benefits comprise net operational cost savings of almost \$126 million, and sales of New Zealand made forest harvesting machinery and equipment (domestic and export) totalling \$111 million, less PGP programme costs of \$7.6 million.

Spillover benefits include improving the safety and quality of the workforce environment (reducing notifiable injury and serious harm incidents by 53% since 2012), developing skills and training, and building technical capability in harvesting machinery manufacturing to future proof the industry. There are now several forest machinery manufacturing companies developing and selling equipment that did not exist in 2010.

The innovations developed by the forestry sector have the potential to further transform forest harvesting and improve economic outcomes substantially for the sector for many years to come.

This transformation will be dependent on further commercialisation and uptake of the forest engineering outputs post-programme. Continued strong support from forest management companies and contractors for increased mechanisation, plus on-going promotion of the work of FGR, will support further adoption of these technology products.

BENEFITS

The cumulative net economic benefits to 30 June 2018 are:

- Operating cost savings of \$125.8 million
- Machinery sales of \$111.3 million
- Total cumulative net economic benefits of \$229.6 million.
- Compared to Business Case total net benefits of \$365.8 million by 2017/18.

On an annual basis the sector-wide net economic benefits in 2017/18 were:

- Operating cost savings of \$46.9 million p.a.
- Machinery sales of \$31.2 million p.a.
- Total annual net economic benefits of \$78.1 million p.a. in 2017/18.
- Compared to Business Case annual benefits in 2017/18 of \$110.8 million p.a.

2. PGP STEEPLAND HARVESTING PROGRAMME

2.1. Programme Goals and Objectives

The primary goal was to reduce the cost of harvesting on steep country by introducing new technology that is more productive and cost effective compared with existing equipment. The secondary goal was to remove workers from the hazardous tasks of manual tree felling, breaking out and unhooking.

The desired programme outcomes were unchanged from the “Innovative Harvesting Solutions” Business Plan prepared for the Primary Growth Partnership (PGP) in February 2010. The total value proposition was to deliver steep country tree harvesting improvements that have a total net economic impact, from baseline 2010 figures, of \$365.8 million by 30 June 2018 through:

- Reducing steep country harvesting cost per tonne by 25% (\$8.00/tonne)
- Eliminating lost time injury (LTI) incidents in felling, breaking out and extraction phases of steep country harvesting operations which adopt this system
- Reducing current energy (diesel fuel) consumption in steep country harvesting by 10%
- Developing and commercially implementing three new machinery types for the forest harvesting industry (felling machine, grapple carriage and innovative yarding system) for both domestic use and export.

There would also be indirect benefits in developing technical capability in harvesting and machinery development; further reducing the environmental footprint of harvesting in New Zealand; and realising the substantial opportunity to increase establishment of forests on marginal lands, most of which are on slopes over 20 degrees.

2.2. Programme Related Activities in 2017/18

Project 1.1 Steep Slope Feller Buncher and Cable Assist Harvesting: This activity saw further development in improving the tractive capacity of ground-based felling machinery on steep slopes, using the winch-assist technology. The PGP programme in this area culminated in the commercialisation of the ClimbMAX Steep Slope Harvester (Figure 1), a single winch-assist unit integrated into the track frame of a felling machine. To date 11 units have been sold, including 8 exported. This machine is commercially available from ClimbMAX Equipment Ltd.

ClimbMAX
INTERNATIONAL LTD WWW.CLIMBMAX.CO.NZ



Figure 1: Commercial model ClimbMAX Steep Slope Harvester

Other sector-wide developments include:

- Tractionline Winch Assist – Dual winch assist system mounted on a hydraulic excavator. To date 71 units have been sold (including 36 exported). This machine is commercially available from EMS Ltd in Rotorua.
- Falcon Hydraulic Winch Assist – a single winch system mounted on a hydraulic excavator. To date 55 units have been sold (including exports). This machine is commercially available from DC Equipment Ltd in Nelson.
- Remote Operated Bulldozer (ROB) – Dual winch assist system mounted on a hydraulic bulldozer. This original concept was designed by logging contractor Lars Rosewarne in partnership with a local engineering firm in Whangarei. To date 32 units have been sold (22 exported). This machine is commercially available from Rosewarne & May Ltd in Whangarei.
- Waka Winch Assist – An excavator-based single winch assist system, based on the original design by logging contractor Bill Winmill. To date 6 units have been sold (all in the South Island). This machine is commercially available from Waka Engineering Ltd in Waikouaiti, Otago.
- Performance Mechanical Winch Assist – a double drum mechanical winch assist system mounted on a Komatsu bulldozer. To date 2 units have been sold (both in NZ). This machine is commercially available from Performance Mechanical & Engineering Ltd in Taupo.

In total 182 winch-assist machines have been manufactured in New Zealand, and approx. 90 units have been exported, mainly to North America. There are now 38 winch-assist machines working in British Columbia, Canada and a further 6 planned as of February 2018 (Table 1).

Table 1: Winch-assist uptake in British Columbia, Canada (Source: FP Innovations, Vancouver).

Winch-Assist Model	Manufacturer	Current (to Feb 2018)	Planned (later in 2018)
Remote Operated Bulldozer (ROB)	Rosewarne & May Ltd, NZ	10	0
ClimbMAX Steep Slope Harvester	ClimbMAX Equipment Ltd, NZ	6	0
Tractionline	EMS Ltd, NZ	5	1
Falcon Winch Assist	DC Equipment Ltd, NZ	4	2
Other (not NZ manufactured)	Various in USA/Canada	13	3
TOTAL		38	6

In addition, research into the operating limits of cable-assist harvesting systems undertaken by the University of Canterbury, School of Forestry to extend the range of operation and reduce risks to the operator led to the development of operator workshops for cable-assist harvesting.

- Dr Rien Visser and Dr Hunter Harrill completed 3 one-day workshops on cable-assist harvesting in Australia in December, 2017.

Project 1.1 HarvestNav machine navigation system: Development in this area commenced as a decision support application for a computer tablet to provide operators of steep slope machinery with real-time information on machine slope and stability and reduce operator hazards. Initially released as a free download ‘app’, HarvestNav was later redesigned and repackaged as a commercial ‘out-of-the-box’ on-board machine navigation system, complete with tablet with pre-loaded software and mounting bracket.

Programme developments during the year included:

- Dr Hamish Marshall of Margules Groome completed development of the new version of HarvestNav in August 2017. This was launched at Harvest Tech 2017 and demonstrated at the field demonstration in Nelson.

- HarvestNav machine navigation system is now commercially available from Margules Groome Ltd. To date 18 have been implemented as the downloaded 'app' and 2 new commercial 'out-of-the-box' on-board machine navigation systems have been sold, complete with tablet with pre-loaded software and mounting bracket.



Figure 2: Commercial model HarvestNav

Project 1.2 (Task A) Teleoperated Felling Machine: This project employed remote control and teleoperation to a commercial model feller buncher, removing the operator from the machine on the steep slope, without sacrificing the worker's productivity. Teleoperation of forestry machines became feasible with off-the-shelf computing and networking hardware. Two 'real world' applications used part of this research: the John Deere 909 project, and the Volvo 290 mobile tail hold project. The first application converted a John Deere model 909 feller buncher to firstly remote control, then subsequently full teleoperation. This trailer-based teleoperation control system for the John Deere 909 feller buncher is now commercially available from Applied Teleoperation Ltd, Rotorua.



Figure 3: Commercial model Full Teleoperation

The second commercial application, called the ATL Cab Assist Backline, is a teleoperation control system for a mobile tail hold machine, enabling the yarder operator to shift the tail hold machine from the yarder cab. The first unit has been sold and is commercially available from Applied Teleoperation Ltd.



Figure 4: Mobile tail hold machine for CAB system

Programme developments during the year included:

- Dr Paul Milliken of Applied Teleoperation Ltd completed commercialisation of the Full Teleoperation product and the Cab Assist Backline (CAB) in August 2017. Both these systems were demonstrated at the field demonstration in Nelson.
- Wood Contracting Ltd declined to purchase the Teleoperation Control System. This system was de-installed from the 909 feller buncher in Nelson in late 2017.
- An agreement was signed with Applied Teleoperation Ltd in March 2018 for ATL to act as agent for FGR to sell the teleoperation control system.
- The Cab Assist Backline system was commissioned after the field demo in Nelson in August 2017 at Wood Contracting Nelson Ltd, which subsequently purchased the first unit.

Project 1.2 (Task B) Robotic Tree-to-tree Felling Machine: This project developed an original concept for an alternative mobility system for a felling machine, using movement from tree-to-tree to traverse across steep terrain. The concept for a robotic tree-to-tree traversing machine (the 'Stick Insect'), was initiated by Scion New Zealand, and further developed into a light weight, remote controlled prototype as part of the Mechatronics Programme at the University of Canterbury. The proof-of-concept prototype was demonstrated in the field to the forest industry in September 2016. Further investment is required to take this development further to commercialisation.

Programme developments during the year included:

- Further attempts were made to identify a commercial partner for further development of the Tree-to-Tree machine. Discussions were held with Scott Technologies Ltd, and In Fact Ltd, however both companies considered the project too early stage and too risky to invest further.
- As of April 2018 all attempts to identify a commercial partner for the Tree-to-Tree machine had proved unsuccessful. No further progress has been made in this project during the year, as there was no further funding available.
- A presentation was made by Dr Richard Parker at the 6th International Forest Engineering Conference (FEC 2018) to promote international interest.
- An animation of the operation of the Tree-to-Tree machine in various applications was presented to the Woodflow 2018 Conference in Rotorua in June 2018.



Figure 5: Prototype tree-to-tree machine

Project 2.1 Advanced Hauler Vision System: This project involved commercialisation of the CutoverCam hauler vision system, a camera located in the harvested cutover (Figure 6). The CutoverCam is an in-cab hauler vision system streaming live video of the log extraction site to the hauler operator. Commercially available from Applied Teleoperation Ltd, to date 4 systems have been sold.

Programme developments during the year included:

- Dr Paul Milliken of Applied Teleoperation Ltd completed development of the new version CutoverCam in 2017-18.
- The ATL CutoverCam was demonstrated at the Pacific Logging Congress conference in Arizona in November 2017. The CutoverCam also featured at the PGP Expo on 30 November 2017, and at the 6th International Forest Engineering Conference in Rotorua in April 2018.
- ATL has confirmed interest from C&C Logging in Oregon to be the North American agent for the CutoverCam.



Figure 6: Commercial model CutoverCam

Other sector-wide developments included:

- Falcon Grapple Camera – an Ag-Cam camera mounted in a rugged box mounted above the mechanical grapple of a cable hauler. It is remotely controlled from the hauler cab for improved productivity of grapple extraction. The Falcon Grapple Camera was designed and built by DC Equipment Ltd (Nelson) and to date about 50 units have been sold for mechanical grapples on swing yarders
- Hawkeye Grapple Camera – integrated into the Hawkeye Grapple Carriage this digital camera system also features LED lighting. Commercially available from EMS Ltd (Rotorua). To date 20 units have been sold (including exports).
- In total, 120 new camera systems (including CutoverCam) have been sold in New Zealand

Project 2.2 Improved Grapple Control System: This project culminated in the commercialisation of the remote controlled light weight hydraulic Alpine Grapple Carriage, developed by Alpine Logging Equipment Ltd of South Africa. The original prototype grapple was trialled in New Zealand to identify modifications for further improvement for New Zealand conditions. To date 13 units have been sold in NZ.



Figure 7: Commercial model Alpine Grapple Carriage

Other sector-wide developments included:

- Falcon Claw Grapple Carriage – a motorised hydraulic grapple carriage, developed by DC Equipment Ltd (Nelson). To date 42 units have been sold (including exports).
- Hawkeye Grapple Carriage – a motorised hydraulic grapple carriage, developed by EMS Ltd (Rotorua). To date 20 units have been sold (including exports).
- In total, 75 new Alpine, Falcon and Hawkeye grapple carriages have been sold, with 60 sales in New Zealand.

This project also completed fundamental work in cable rigging configurations and tension monitoring of different cable systems (including the Falcon Forestry Claw grapple developed by DC Equipment Ltd of Nelson). Research into the operating limits of skyline harvesting systems and cable-assist harvesting systems undertaken by the University of Canterbury, School of Forestry has led to the development of a tension monitoring 'app' to be used in conjunction with a tension monitor to extend the range of operation and reduce risks to the operator.

- The Falcon Tension Monitoring System (Figure 8) is being commercialised by DC Equipment Ltd. The first integrated system was installed in the Falcon 60 yarder at Marlborough Harvesting Ltd in January 2018. This prototype is scheduled for commercial launch later in 2018.



Figure 8: Prototype Falcon Tension Monitoring System

Project 2.3 Innovative Yarding System: This project, investigating alternative new extraction systems and methods to reduce cycle time, provide improved lift, and reduce operational delays, was aimed at developing a totally new concept yarding system. A common theme from the Innovative Yarding workshops, held in a number of regions throughout New Zealand, was the difficulty and cost of cable skyline shifting. This project developed an innovative twin winch tail hold carriage (the Skyshifter) designed for rapid shifting of the skyline (Figure 9).



Figure 9: Prototype model Skyshifter twin winch tail hold carriage

- A New Zealand patent for the Skyshifter has been filed based on PCT/NZ2015/050036, Title: Cable logging system.
- FGR and Awdon have signed a development agreement, whereby Awdon agrees to pay a royalty to FGR for each carriage sold before 30 June 2021.
- The unit is now available as a “lease as required” model, to enable contractors to use the equipment as and when required, or for sale from Awdon Technologies Limited.
- Awdon Technologies Ltd is now seeking a commercial partner to take the prototype to full commercial stage, and to collaborate in further developments of tail hold carriages to improve cable yarding operations.

Project 3.2 Doherty Quick Coupler: This project arose from the Harvesting Technology Watch investigating new technologies internationally, and supporting the development of opportunistic projects. The Doherty automatic quick coupler is a hydraulic quick coupling attachment that enables rapid changeover from grapple processor head to log loading grapple, without the operator having to leave the cab of the base machine. The Quick Coupler was designed and built by Doherty Engineered Attachments Ltd of Mount Maunganui (Figure 10).

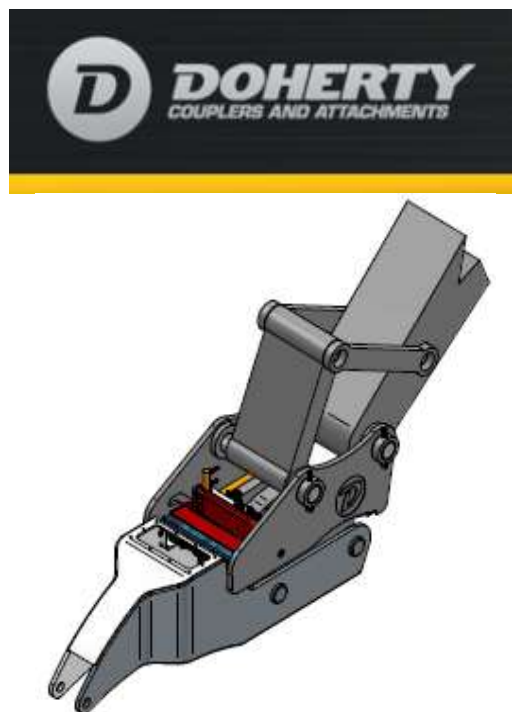

Figure 10: Commercial model Doherty Quick Coupler

Programme developments during the year included:

- Further resources to complete the Quick Coupler modification were reallocated to this project in October 2017.
- The first unit has been sold and is commercially available from Doherty Engineered Attachments Ltd and serviced by Total Hydraulic Solutions Ltd (Rotorua).
- The first unit is ready for installation in the base machine of the first adopter contractor.

Project 3.2 Harvesting Cost and Productivity Benchmarking: This project comprised the development of a comprehensive Harvesting Cost and Productivity Benchmarking database in 2008. The database comprises confidential harvest area production information, including terrain, forest stand, harvesting crew and cost data contributed by industry co-investors. It provides a system to track productivity and cost in NZ harvesting systems, as well as understanding the drivers of harvesting productivity and cost.

Continued development of the Benchmarking database provides a mechanism to record and monitor trends in levels of mechanisation, and deliver productivity and cost regression equations, recording the important productivity and cost factors over time.

Programme developments during the year included:

- New techniques including Data Envelope Analyses and Stochastic Frontier Analyses were explored by University of Canterbury to provide more in-depth efficiency analyses of individual contracting crews and/or system types.
- The FGR harvesting cost and productivity benchmarking database was expanded by 153 new entries in 2017, and the total dataset now contains 1406 entries over a period of ten years.
- Forest Growers Research signed a contract variation in November 2017 for the extension of the Harvesting Benchmarking Project until 18 November 2025.

3. OUTCOMES

There has been significant progress towards achievement of both short and medium-term outcomes. Outputs of the PGP Steep Land Harvesting programme to date have been recognised by the forest industry in New Zealand as contributing to increased productivity and reduced exposure of workers to hazards on steep terrain.

3.1. Short Term Outcomes

The short term outcomes from the programme are:

- commercialisation of new products and processes that improve productivity and reduce the cost of steep land harvesting
- commercialisation of new products and processes that reduce dangerous manual labour roles in steep land harvesting
- new opportunities for New Zealand made forest harvesting machinery in domestic and export markets.

The timeframe for achievement of the short-term outcomes is 2018, only one year after programme completion. Delivery of these short term outcomes has been excellent. The programme has been extremely successful in catalysing development of technologies across the sector that have increased the rate of uptake of mechanisation, improved productivity and reduced the number of serious harm injuries in forestry in New Zealand.

As of June 2018, sector-wide there have been 21 projects to develop new harvesting products over the last five years. These projects have delivered seven commercialised products and three prototypes from the PGP programme, and nine commercialised products and one prototype from other developments outside the PGP programme. Many of these developments across the sector were catalysed by success of projects within the PGP programme. This is a commercialisation strike-rate of 75%, significantly higher than most engineering development and commercialisation programmes.

Sector-wide commercialised products:

- ClimbMAX Steep Slope Harvester – ClimbMAX Equipment Ltd (PGP)
- Tractionline Winch Assist – Electrical & Machinery Services Ltd
- Falcon Hydraulic Winch Assist – DC Equipment Ltd
- Remote Operated Bulldozer (ROB) – Rosewarne & May Ltd
- Waka Winch Assist – Waka Engineering Ltd
- Performance Mechanical Winch Assist – Performance Mechanical & Engineering Ltd
- ATL Full Teleoperation – Applied Teleoperation Ltd (PGP)

- Alpine Grapple Carriage – Logpro Ltd (PGP)
- Falcon Claw Grapple Carriage – DC Equipment Ltd
- Hawkeye Grapple Carriage – Electrical & Machinery Services Ltd
- HarvestNav machine navigation system – Margules Groome Ltd (PGP)
- CutoverCam hauler vision system – Applied Teleoperation Ltd (PGP)
- Falcon Grapple Camera –DC Equipment Ltd
- Hawkeye Grapple Camera – Electrical & Machinery Services Ltd
- ATL Cab Assist Backline (CAB) – Applied Teleoperation Ltd (PGP)
- Doherty Quick Coupler – Doherty Engineered Attachments Ltd (PGP)

Prototypes in various stages of commercialisation:

- Robotic Tree-to-tree Felling Machine – Scion (PGP)
- Falcon Tension Monitoring System – DC Equipment Ltd (PGP)
- Skyshifter twin winch tail hold carriage – Awdon Technologies Ltd (PGP)
- Falcon Felling Carriage – DC Equipment Ltd.

3.2. Medium Term Outcomes

The medium term outcomes expected from the programme are:

- New Zealand forest industry using improved steepland harvesting products and processes.
- Higher productivity and profitability in New Zealand steepland harvesting
- Safer New Zealand steepland harvesting operations
- Growth in the forest harvesting machinery manufacturing sector in New Zealand

Uptake of steepland harvesting products and processes

The programme has resulted in the successful commercialisation and uptake of new harvesting products and processes. Since commercialisation of the ClimbMAX harvester in 2012 and widespread uptake of 90 other winch-assisted machines over the last five years, the level of mechanised tree felling in hauler operations (as reported in the FGR Benchmarking database) has increased to 35% of operations, up from only 1% in 2010 (Figure 11). Increased uptake of feller bunchers in ground-based operations has increased mechanised felling on flat land to over 80% of operations. Over all harvesting operations mechanised felling averages about 55% (up from 23% of all operations in 2010).

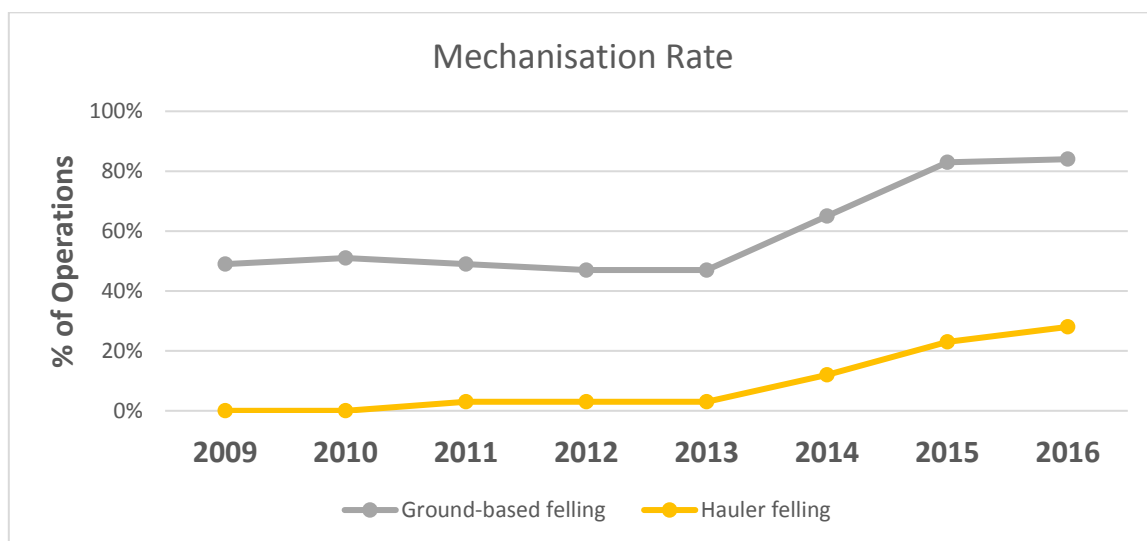

Figure 11: Increase in mechanised felling since 2013

Regarding cable hauler extraction systems, a recent update to the yarder and rigging configurations surveys last undertaken in 2011/12 shows there has been a large reduction in manual rigging configurations (North Bend/scab skyline/highlead) down from 76% of operations in 2012 to 29% in 2018. Conversely there has been a large increase in the use of grapples (both mechanical and motorised) from 4% in 2012 to 55% in 2018. A summary of this data was presented by Dr Hunter Harrill of University of Canterbury School of Forestry at the recent 6th International Forest Engineering Conference in Rotorua in April.

Higher productivity in New Zealand steepland harvesting

To date the industry uptake of winch-assisted felling machinery on steep slopes, and increased uptake of grapple yarding as an improved method of cable log extraction, has achieved productivity increases of 25% increase in cable harvesting productivity since 2013 (29.4 tonnes/hour in 2016 vs. 23.4 tonnes/hour in 2013 – FGR Benchmarking).

In addition the increase in mechanised felling and processing in ground-based operations has seen a 33% increase in ground-based productivity since 2013 (36.8 tonnes/hour in 2016 vs. 27.7 tonnes/hour in 2013 – FGR Benchmarking).

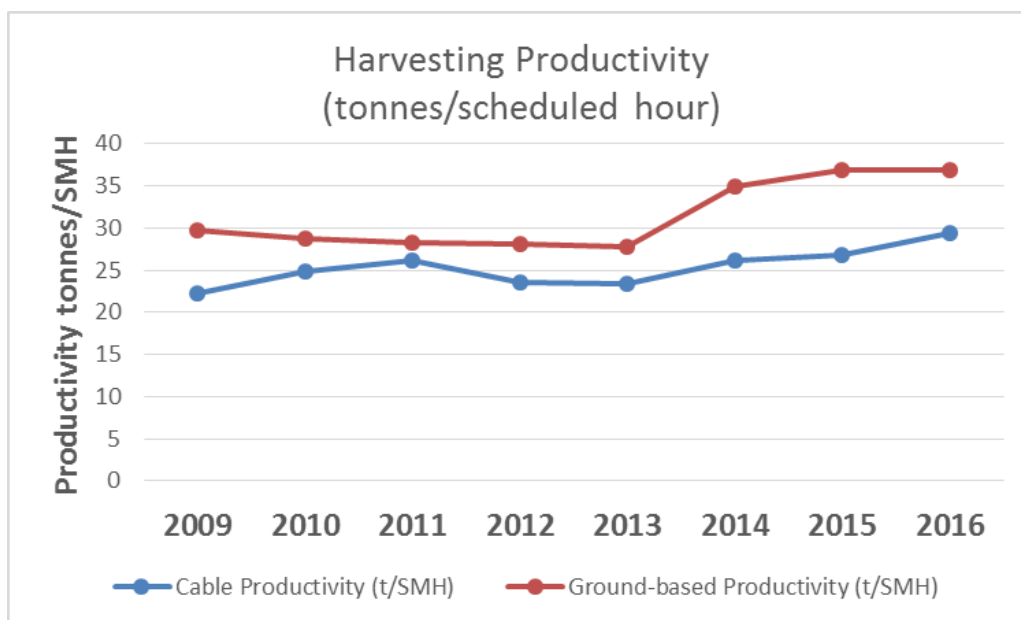

Figure 12: Increased harvesting productivity since 2013

Safer New Zealand steepland harvesting operations

As a result of forest industry safety initiatives arising from the Independent Forestry Safety Review in 2014 and developments in the Steepland Harvesting PGP programme and outside the programme, forestry companies and harvesting contractors have implemented the new winch-assist mechanised harvesting technology, and increased uptake of hydraulic grapples and mechanised processing. This technology now provides a safe alternative to manual tree felling with chainsaws, manual breaking out and manual log processing by isolating workers from hazards.

From 2012 to 2018 there has been major investment in new harvesters, winch-assist machinery, grapples, cameras and other equipment designed to enable safe work in steep slope forests. Mechanised felling is now replacing manual tree fallers wherever possible in corporate forests and starting to be introduced in small forest operations. These innovations are providing forest owners and contractors with solutions to improve productivity and reduce the exposure of workers to hazards on steep terrain.

The combined result of increased focus by WorkSafe NZ, increased injury prevention funding and a step change in harvesting mechanisation, the number of notifiable injury and serious harm incidents (SHI) per year in forestry has seen a 53% reduction from 174 SHI in 2012 to 82 SHI in 2017 (Table 2).

Table 2: Forestry and logging notifiable injury and serious harm incidents incidents/fatalities
(Source: WorkSafe NZ)

Year	Serious Harm Incidents (including fatal)	Fatalities	Roundwood removals (Mm3)
2012	174	6	26.05
2013	147	10	28.15
2014	88	1	30.23
2015	69	3	29.56
2016	86	4	28.51
2017	82	7	30.59

From 2012 to mid-2018 it is estimated that 213 workers have been removed from hazardous manual felling and breaking out roles. Even more striking – the rate of serious harm incidents per million cubic metres of wood production has dropped to less than one-third of the rate in 2012, from 7.2 to 2.4 (Figure 13). This is measured against annual round wood removals from data collected by Ministry for Primary Industries, and the number of serious harm incidents as recorded by WorkSafe NZ. Over this period annual forest harvest volumes have lifted from 26.0 million cubic metres per annum in 2012 to 30.6 million p.a. in 2017 (+18%).

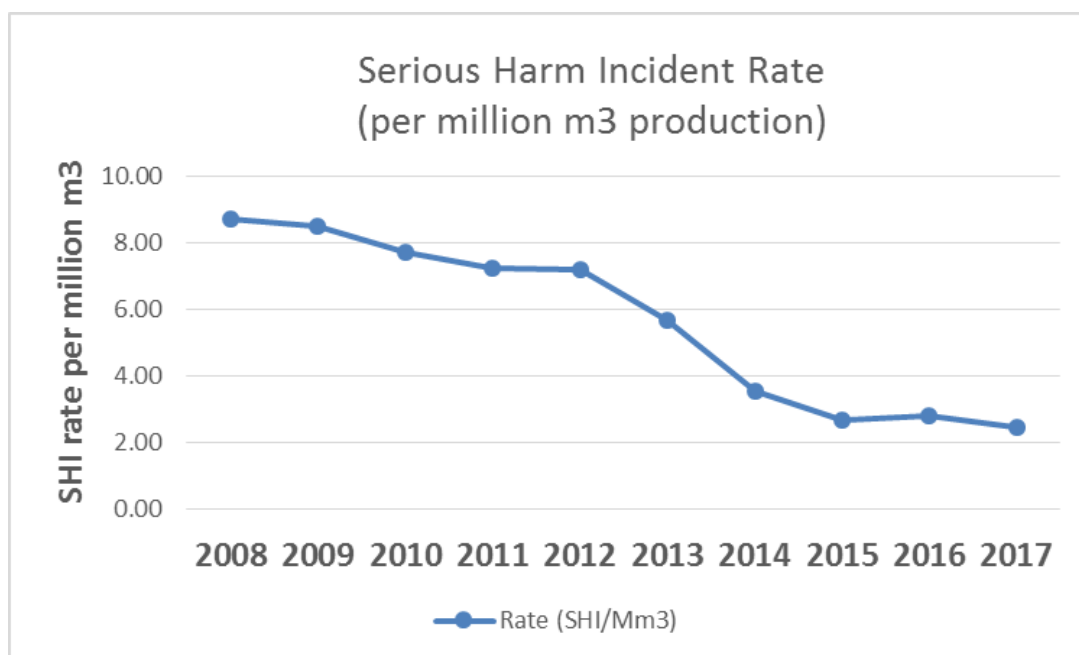

Figure 13: Improved rate of Serious Harm Incidents per million cubic metres production

Commercial outcomes for Machinery Manufacturers

There are now four main New Zealand companies manufacturing about 20-25 winch-assist machines between them annually. There are now two manufacturers of remote controlled hydraulic grapples in New Zealand (DC Equipment Ltd.'s Falcon Claw and E.M.S. Ltd.'s Hawkeye).

One company (DC Equipment Ltd of Nelson) has built and sold 42 Falcon Forestry Claw grapple carriages and over 100 grapple camera systems, including a new product called Skylight.

E.M.S. Ltd of Rotorua has launched a new hydraulic grapple called Hawkeye with an integrated grapple camera system (20 sales) and T-Mar Industries Ltd of British Columbia has also sold 6 grapple camera units in New Zealand.

4. BENEFITS

4.1. Economic Benefits

Table 3 shows the actual direct economic benefits arising from the programme versus those envisaged in the original business plan.

Table 3: Economic Benefits – Budget vs. Actual (2017/18 highlighted)

Benefit	Year	2010/11	2011/12	2012/13	2013/14	2014/15	2015/16	2016/17	2017/18
Operating Cost Savings (\$M p.a.)	Budget	0.0	6.1	14.3	25.0	38.4	54.5	65.4	78.2
	Actual	0.0	1.7	3.7	6.8	12.6	22.1	32.1	46.9
Fuel Savings (\$M p.a.)	Budget	-0.2	-0.5	0.0	0.8	2.2	4.1	4.7	5.2
	Actual	0.0	0.0	0.0	0.0	0.0	0.0	0.0	0.0
Injury Claim Savings (\$M p.a.)	Budget	0.0	0.1	0.1	0.2	0.3	0.4	0.4	0.4
	Actual	0.0	0.0	0.0	0.0	0.0	0.0	0.00	0.0
Annual Machinery Sales (\$M p.a.)	Budget	0.0	1.6	3.4	5.3	7.9	11.6	16.3	26.8
	Actual	0.0	3.0	3.2	6.4	13.8	23.1	30.7	32.2
Total Annual Net Benefits (\$M p.a.)	Budget	-1.1	6.5	16.6	30.2	47.6	69.4	85.8	110.8
	Actual	-0.9	3.9	6.0	11.9	25.2	43.6	61.7	78.1
Cumulative Net Benefits (\$M)	Budget	-1.1	5.4	22.0	52.2	99.8	169.1	255.0	365.8
	Actual	-0.9	3.0	9.0	20.9	46.1	89.7	151.4	229.5

The original business plan (plus one-year extension) envisaged annual net economic benefits in 2017/18 of \$110.8 million p.a. as well as enhanced worker safety. Annual net economic benefits for 2017/18 are calculated to be \$78.1 million (70% of target benefits). Cumulative net sector wide benefits arising both directly from the programme and from related outputs total \$229.5 million to 30 June 2018. These benefits comprise cumulative operational cost savings of \$125.8 million, plus domestic and export sales of New Zealand made forest harvesting machinery and equipment totalling \$111.3 million less programme costs of \$7.6 million.

Outputs of the PGP Steep Land Harvesting programme to date have been recognised by the forest industry in New Zealand as contributing to increased productivity and reduced exposure of workers to hazards on steep terrain. The annual rate of benefit gain from the programme is illustrated in Figure 14.

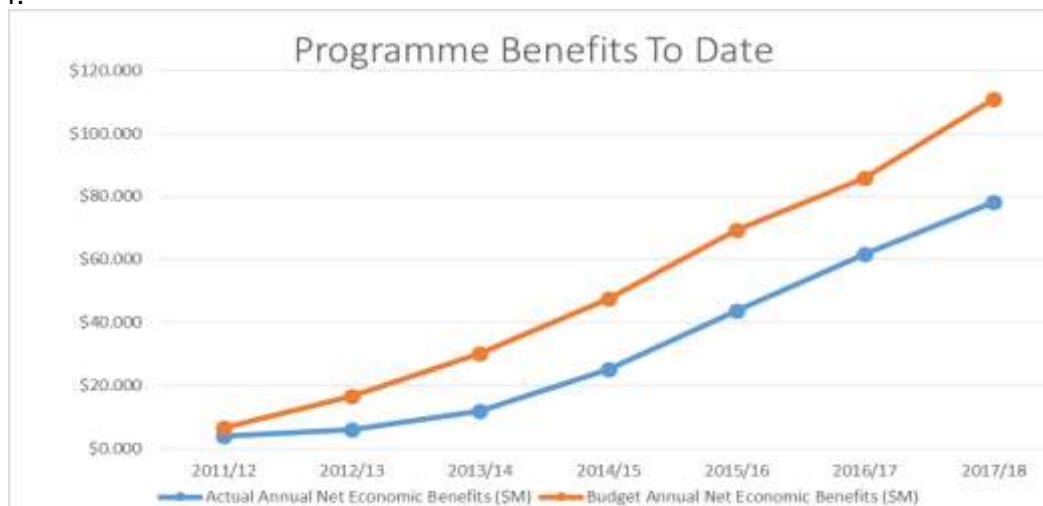

Figure 14: Annual Net Economic Benefits Actual vs. Budget

4.2. Forest Machinery Sales

Sector wide benefits include the development, commercialisation and sale of 182 new winch-assist felling units (including about 90 machine exports to North and South America) since 2012. Other related benefits include development of new types of grapples and grapple camera systems. The use of grapples has increased rapidly since 2012, when only 17 mechanical grapples (and no hydraulic grapples) were in operation. Latest estimates are that over 100 grapples are in operation (including 60 new Alpine, Falcon or Hawkeye grapple carriages, and over 50 mechanical grapples).

As of June 2018 the following NZ-manufactured machinery and equipment has been sold:

- ClimbMAX harvesters – 11 units sold (3 in NZ)
- TractionLine winch-assist – 71 sold (35 in NZ)
- Falcon winch-assist – 55 sold (32 in NZ)
- Remote Operated Bulldozer (ROB) – 32 sold (10 in NZ)
- Other NZ-made winch-assist machines – 13 built and operating in NZ
- 42 Falcon Claw, 20 Hawkeye and 13 Alpine grapple carriages sold
- 20 HarvestNav navigation units in operation
- Over 100 hauler vision systems sold (including CutoverCam, Falcon and Hawkeye grapple cams)

From 2012 to 2018 over \$111 million has been invested by industry in new harvesters, winch-assist machinery, grapples, cameras and other equipment designed to increase productivity and enable safe work in tree felling and extraction.

4.3. Spillover Benefits

Spillover benefits from the programme have been a large number of training workshops undertaken by the School of Forestry, University of Canterbury in working on steep slopes with cable-assist harvesting. During the last year Dr Rien Visser and Dr Hunter Harrill of the University of Canterbury have organised a further three one-day training workshops on cable-assist harvesting in Australia in December, 2017. The School of Forestry have also planned continuing professional development courses in forest engineering, harvest planning, LiDAR analysis and cable-assisted harvesting in August 2018, which will foster uptake of the Steepland Harvesting Programme outputs.

The programme has been successful in building technical capability in harvesting machinery development. The programme has supported the business development of four technology developers (Applied Teleoperation Ltd, Awdon Technologies Ltd, Logpro Ltd and Margules Groome Consulting Ltd) in addition to three machinery manufacturing companies (ClimbMAX Equipment Ltd, Doherty Engineered Attachments Ltd and DC Equipment Ltd).

The programme has achieved a high level of recognition internationally through participation in international conferences, and strong industry collaboration with research organisations such as FPInnovations in Canada and Skogforsk, the Forestry Research Institute of Sweden. FPInnovations have continued their Steep Slope Initiative in winch-assisted harvesting. This has driven further exports of New Zealand manufactured winch-assist machinery and contribute to the expansion of the New Zealand machinery manufacturing sector, a key objective of the PGP programme. FGR signed an extension to the Memorandum of Understanding with FP Innovations in July 2018 to continue our close working relationship.

5. POST PGP PROGRAMME ACTIVITIES

5.1. Other Activities

There have been a number of collaborative developments that have occurred post-programme:

- Falcon Felling Carriage prototype developed by DC Equipment Ltd. This was released at HarvestTECH 2017 in Rotorua in June 2017, and is currently being trialled. It is planned for commercial production and sale later in 2018.

- Continued commercialisation work of products arising from the programme, such as the teleoperated systems, the CutoverCam and the Doherty Quick Coupler.
- Further extension and promotion to forest industry stakeholders of the work of FGR through industry conferences. Examples are the 6th International Forest Engineering Conference in April 2018 and the Woodflow 2018 Conference in June 2018.
- Continued funding by FGR of University of Canterbury projects in benchmarking harvesting cost and productivity, utilisation of winch-assist machinery, roading planning, cable yarder and rigging configurations survey.
- Continued funding of FGR through the Forest Grower Levy Trust to develop a new programme in forestry automation and robotics applied further down the forestry value chain to continue the momentum generated by this programme.

All these activities will promote further commercialisation and uptake of outputs from the PGP Steepland Harvesting Programme.

5.2. Conclusions

- The programme has continued to catalyse increased innovation in harvesting in New Zealand with new technology being developed and deployed, both from the programme and outside of the programme.
- The programme continues to deliver benefits to New Zealand through a continued investment programme by the forest industry in 2017/18.
- Programme outputs continue to be well promoted and communicated to the industry through continued Technical Steering Team meetings and industry conferences. This ongoing communication will continue to promote uptake and adoption of outputs of the Steepland Harvesting programme.
- The programme has achieved a high level of recognition internationally through participation in international conferences (such as the recent 6th International Forest Engineering Conference, held for the first time in New Zealand). As a result of the programme and other sector developments, New Zealand has taken a leadership role in the development of mechanised forest harvesting operations on steep slopes.
- The programme has the potential to further transform the forest harvesting industry and improve economic outcomes in the forestry and forest products sector for many years to come. This transformation will be dependent on further commercialisation and uptake of the outputs of the forest engineering outputs of this programme, combined with strong support from forest management companies driving further adoption.

5.3. Further Post-programme Reporting

An annual programme outcomes report detailing progress towards achieving short term outcomes (to June 2018) and medium term outcomes (from 2019 on) will be prepared by Forest Growers Research and submitted to MPI within one month of the periods ending 30 June 2019, and 30 June 2020.

5.4. Programme Evaluation

A requirement of the Primary Growth Partnership (PGP) Contract as detailed in the 2016/17 Annual Plan was that the Ministry for Primary Industries (MPI) would undertake a separate independent evaluation of the Steepland Harvesting PGP Programme. This evaluation was undertaken by Chris Nixon of NZIER and presented to stakeholders in the programme on 29 June 2018.

6. REPORTS AND CONFERENCE PRESENTATIONS 2017/18

1. Brown, K., and Visser, R. (2017): "Adoption of Emergent Technology for Forest Road Management in New Zealand". Report H033 Forest Growers Research Ltd. 25 May 2018.
2. Forest Growers Research Ltd (2017): Quarterly Report for the period 1 April to 30 June 2017, prepared for the Programme Steering Group, August 2017. Forest Growers Research Ltd.
3. Forest Growers Research Ltd (2017): "Steep Land Harvesting Programme: Final Programme Report". Report H032 Forest Growers Research Ltd. 30 September 2017.
4. Harrill, H. "Cable Yarders and Rigging Configurations in New Zealand: A 2018 Update". Presentation to the 6th International Forest Engineering Conference, Rotorua, New Zealand, 17 April, 2018.
5. Harrill, H., Reriti, B. and Visser, R. "Utilisation of Winch-Assist Machines". Harvesting Technical Note HTN10-03 Forest Growers Research Ltd. 2018.
6. Milliken, P. "Applying teleoperation and vision systems to facilitate a safer and more productive workplace". Presentation to the 6th International Forest Engineering Conference, Rotorua, New Zealand, 19 April, 2018.
7. Parker, R. "Tree Locomotion Robot". Presentation to the 6th International Forest Engineering Conference, Rotorua, New Zealand, 19 April, 2018.
8. Raymond, K. "Harvesting Programme Update" Issue No. 31, Forest Growers Research Ltd. November 2017.
9. Raymond, K. "Harvesting Programme Update" Issue No. 32, Forest Growers Research Ltd. February 2018.
10. Raymond, K. "Forest Engineering Developments in New Zealand". Presentation to the 6th International Forest Engineering Conference, Rotorua, New Zealand, 17 April, 2018.
11. Reriti, B. "Determining long-term machine utilisation using GPS tracking: A Pan Pac Case Study". Presentation to the 6th International Forest Engineering Conference, Rotorua, New Zealand, 17 April, 2018.
12. Spinelli, R. and Harrill, H. (2018): "Integrated biomass harvesting for New Zealand operations". Harvesting Technical Note HTN10-01 Forest Growers Research Ltd. 2018.
13. Visser R. "Autonomous Extraction Systems". Presentation to the 6th International Forest Engineering Conference, Rotorua, New Zealand, 19 April, 2018.
14. Visser R. "Benchmarking Harvesting Cost and Productivity – 2017 Update". Harvesting Technical Note HTN10-02 Forest Growers Research Ltd. 2018.